

Overview

Tube motor support 50.50 square tubes - for RB 50, TGU tube motor

Product number: 25250021

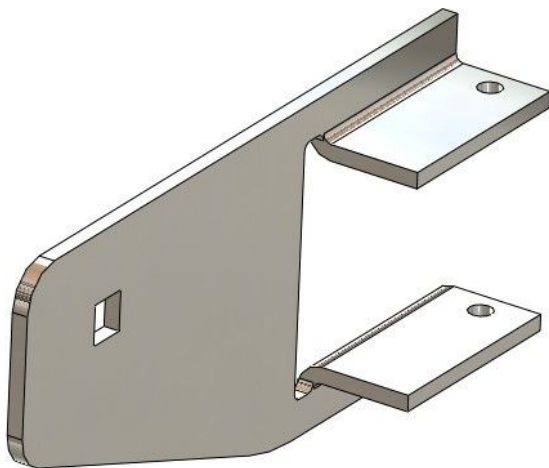

Options

Version

E+

RB50 / FRM 50

RB120



TGU GmbH & Co. KG
Joseph-Monier-Str. 2
48268 Greven
Deutschland

Kontakt:
Telefon: +49 2575/95587-
15
Fax: +49 2575/95587-87
E-Mail: info@tgu-shop.com

Rechtliches:
Amtsgericht Ibbenbüren
USt-ID-Nr.:
DE 125543036

Description

- **Application:** Shaft support for suspended shading systems with gable drive
- **Material:** Hot-dip galvanized steel for high stability and corrosion resistance
- **Installation:** Square tubes are flanged directly onto the motor support
- **Special feature:** Easy installation without manual alignment of the drive shaft
- **Compatibility:** Suitable for RB 50 and FL 50 tube motors
- **Scope of delivery:** Bolts and nuts not included

The **Tube Motor Support 50.50** positions the drive shaft precisely for the motor system and simplifies installation thanks to its intuitive handling. It is ideal for suspended shading systems with gable drive. Square tubes are mounted directly onto the support, eliminating the need for manual shaft alignment. The galvanized steel construction ensures long-term durability and corrosion protection.